



INSTALLATION INSTRUCTIONS

Product: B1 Body Lift™

Part Number: JKS9903

Applications: Wrangler YJ, 1987-95

517-278-1226 • tech@jksmfg.com • www.jksmfg.com
491 W. Garfield Avenue, Coldwater, MI 49036

Welcome

Congratulations on purchasing a new B1 Body Lift from JKS® Manufacturing. We are committed to providing you with the best products available and your satisfaction is our first priority.

We hope you enjoy your JKS® purchase and are here to help if you still have questions after reviewing this safety information and instructions. Contact us online at www.jksmfg.com or by phone at 877-533-7557.

Tools Required

- Metric/Standard Socket Wrench Set
- Torque Wrench
- Tape Measure
- Philips Screwdriver
- Medium Strength Threadlocker
- Hydraulic Floor Jack
- Sturdy Block of Wood (to protect body)
- Center Punch and Hammer
- 3/16" and 7/32" Drill Bits
- 1/4" NF Tap *
- Reciprocating Saw or Die Grinder with Cut-Off Wheel * (for trimming fan shroud)
- Factory Service Manual (recommended)

* Asterisk denotes tools that are not required for some applications. Thoroughly read instructions first to determine which tools will be required for your application.



Always Wear Protective Gear
Safety glasses and protective gloves are required.

Parts



	Description	QTY
A	Dura-Thane™ Body Puck	11
B	1/2" x 4-1/2" Bolt	6
C	1/2" Flat Washer	6
D	7/16" x 4" Bolt	5
E	7/16" Flat Washer	5
F	Extended Radiator Bumper	2

NOTICE

One Side At A Time

Body lift must be installed on one side of vehicle at a time.

Motor Lift Recommended

Installation of JKS Motor Lift in conjunction with B1 Body Lift is recommended. This will make steps 2, 6 and 7 unnecessary.

Install body lift first if installing motor mount lift and body lift at the same time.

Important Product Safety Information

For your safety and the safety of others, please read all instructions and warnings in this pamphlet and your Jeep® owner's manual and off road driving supplement before attempting installation. Within these instructions the following signal words refer to important product safety information:

WARNING

Indicates hazards or unsafe situations which could result in **severe personal injury or death**.

CAUTION

Indicates hazards or unsafe situations which could result in property damage or minor to moderate personal injury.

NOTICE

Careful attention is required to this operation that generally does not relate to personal injury, although damage to your JKS product or other property may result if you fail to follow instructions.

WARNING

Higher Rollover Risk



Modifying your Jeep® to improve off-road performance may result in vehicle handling different than as factory equipped, including increased ride-height and/or chassis articulation; reduced lateral stability and higher risk of roll-over or other accident. Also, owner's choice of larger tire and wheel combinations may require additional braking force or increased stopping distances.

To reduce risk of serious injury and accident:

- Choose modifications that balance your actual highway & off-road use.
- Avoid sharp turns, abrupt maneuvers or steep side-cambers.
- Avoid other maneuvering conditions which may cause the vehicle to trip, roll, lose traction or compromise your ability to safely brake in an emergency.
- Routinely inspect your vehicle components for unusual wear or off-road damage. Repair or Replace any unserviceable components before use.
- Do not modify or combine body lifts with other mechanical lifts contrary to manufacturers' or Jeep® recommendations & warnings.
- Acquaint any other drivers with your vehicle modifications and handling.
- Always wear seat belts and/or appropriate off-road restraints, reduce your speed, Tread Lightly®.

Installation

1. REMOVE CHASSIS COVER

- Remove the mounting screws from the plastic (JEEP embossed) crossmember cover in front of vehicle grill.
- Remove crossmember cover from chassis rails.
- Remove steel strip in front of grill that holds the steel brake line. Save the two plastic brake line clips for re-installation, and discard steel strip.

2. UNBOLT FAN SHROUD

- Remove the four bolts holding the plastic fan shroud to the steel radiator bracket. Retain hardware for re-installation.

3. LOOSEN BODY MOUNTS

- Locate all eleven body mount bolts on vehicle. Refer to the BODY MOUNT LOCATION DIAGRAM for assistance.
- Loosen each body mount bolt, but DO NOT REMOVE until instructed.
- Remove the bolt from body mount ① located beneath the grill.
- Remove the bolts from body mounts ② ③ ④ ⑤ and ⑥ on DRIVER SIDE of vehicle only.

NOTE: Body mount ⑤ is located between fuel tank and rear axle.

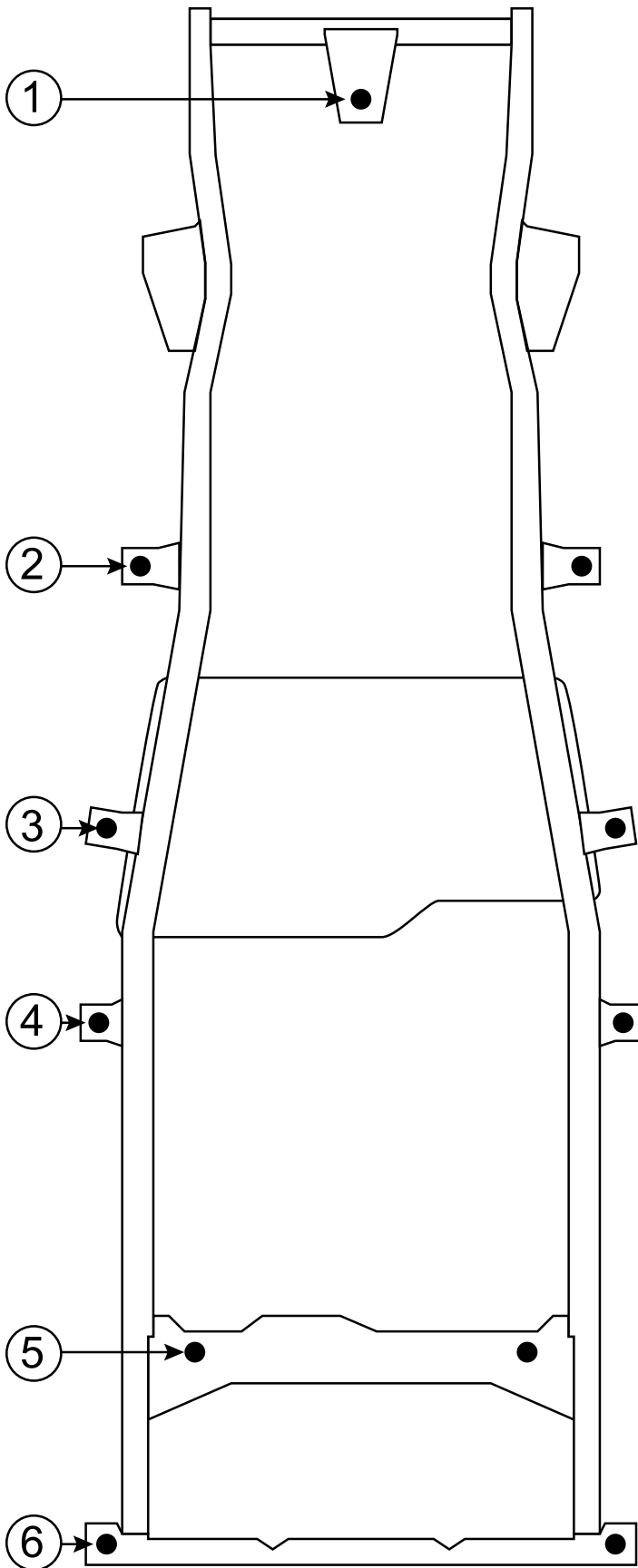

□ **4. INSERT BODY PUCKS**

- Position a hydraulic jack next to body mount ③ on DRIVER SIDE of vehicle.
- Place a sturdy wooden block between the hydraulic jack pad and channel portion of vehicle body for protection.
- Carefully raise the vehicle body just enough to insert the 1.25" Body Pucks (A) between body and factory body mounts ② ③ ④ ⑤ and ⑥.

NOTE: Position Body Pucks with recessed bottom encapsulating the OE body mount.

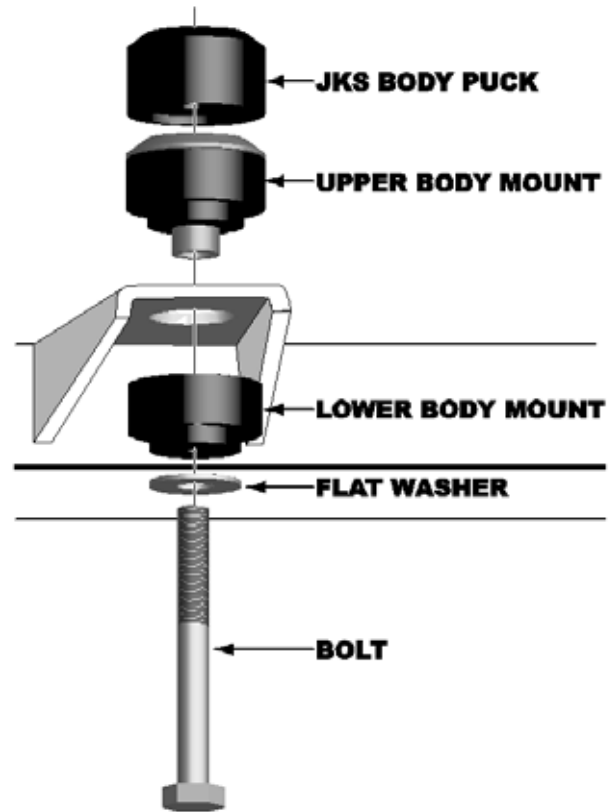

- Locate the factory rubber radiator bumper beneath the grill panel and replace with the supplied Extended Radiator Bumper (F) using the original hardware.
- With Body Pucks (A) and Extended Radiator Bumper (F) inserted, slowly lower the vehicle body onto mounts, ensuring correct alignment of body on chassis.
- Apply medium strength thread locking compound to three of the supplied 1/2" x 4-1/2" Bolts (B) and two of the 7/16" x 4" Bolts (D).
- Insert the 1/2" x 4-1/2" Bolts (B) with 1/2" Flat Washers (C) into body mount positions ② ③ and ④. Insert the 7/16" x 4" Bolts (D) with 7/16" Flat Washers (E) into body mount positions ⑤ and ⑥. Start threads but DO NOT TIGHTEN bolts until instructed.

- Repeat this procedure with body mounts ② ③ ④ ⑤ and ⑥ and Extended Radiator Bumper on the PASSENGER SIDE of vehicle.
- Insert the last remaining Body Puck (A) at body mount ① located beneath the grill.
- Apply medium strength thread locking compound to the last remaining 7/16" x 4" Bolt (D) and insert with a 7/16" Flat Washer (E) into body mount position ①.
- Using a torque wrench, tighten all 1/2" and 7/16" Bolts (B and D) to 30-35 ft-lbs.

Note: Use care when tightening bolts to avoid crushing factory rubber body mounts.

□ 5. SECURE STEEL BRAKE LINE

- Locate the grill support that is welded to the round cross member at front of chassis.
- Drill two 3/16" holes through top of grill support located approximately 3/4" from edge of support and directly in front of the grill.
- Insert the two plastic brake line clips into the 3/16" holes, and then snap the steel brake line into plastic clips.

□ 6. MODIFY RADIATOR

- Locate the four plastic fan shroud mounting holes on the steel radiator bracket.
- Measure exactly 1" below the factory mounting holes and mark the location with a center punch.
- Drill a new 7/32" hole through all four center punched marks.
- Test fit the fan shroud to the radiator by aligning with the new mounting holes.
- Check for interference between the fan shroud and radiator hoses, fan blades, or any other objects. If necessary, trim the fan shroud until it completely clears any interferences.
- Secure the fan shroud to the steel radiator bracket with the original four mounting bolts.

Note: The original bolts may be used to tap the new mounting holes. However, it will be easier to install the bolts if the mounting holes are pre-tapped with a 1/4" NF tap.

□ 7. CHECK T-CASE OPERATION

- Check operation of the shift lever to ensure the transfer case fully engages all ranges.

Note: If necessary, adjust linkage between shift lever and bell crank. If interference is experienced, it may be necessary to trim the floor to provide sufficient shift lever clearance.

□ 8. POST-INSTALLATION

- Check all mounting hardware to ensure it has been correctly installed and tightened to factory torque specifications.
- Check torque specifications for all mounting hardware after driving vehicle 50 miles, and after first time off-road.

Maintenance

Check all torque specifications as part of regular vehicle maintenance schedule.

©2013 JKS Manufacturing, Inc & Aftermarketing, LLC
Revision Date 10/31/2013