



INSTALLATION INSTRUCTIONS

Product: J-Flex Front Upper Control Arm Rebuild Kit
Part Number: JKS7002

Applications:

JKS1652, JKS1615, JKS1616

877-533-7557 • jks@sporttruckusainc.com • www.jksmfg.com
491 W. Garfield Avenue, Coldwater, MI 49036

Welcome

CONGRATULATIONS on purchasing a control arm rebuild kit from JKS Manufacturing. We are committed to providing you with the best products available and your satisfaction is our first priority.

PLEASE READ these Installation Instructions carefully, and save them for future reference, as they contain important installation and maintenance information.

Important

The Flex Joint Rebuild tool Kit (JKS1690) required for installation

Tools Required

- H Frame Shop Press
- Internal snap ring pliers
- JKS1690 Flex Joint Rebuild Tool Kit

Parts

Description	QTY
Small Flex Joint Washer	1
Flex End Bushing	2
1-5/8" Retaining ring	1
J-Flex Decal	1

Installation

□ CONTROL ARM REMOVAL

□ 1. LIFT AND SUPPORT VEHICLE

- Raise and support the vehicle chassis with jack stands.
- Raise and support the axle housing with jack stands
- The axle housing should be evenly supported with the suspension at normal ride height. Do not attempt removal or installation with the suspension extended or the axle drooped, as this will place tension on suspension arm mounting hardware.
- Refer to original installation instructions if necessary.
- Work on one side of the vehicle at a time in order to keep the axle safely supported, remove 1 control arm from vehicle.

□ FLEX JOINT REBUILD

□ 1. ASSEMBLE TOOL TO FLEX EYE

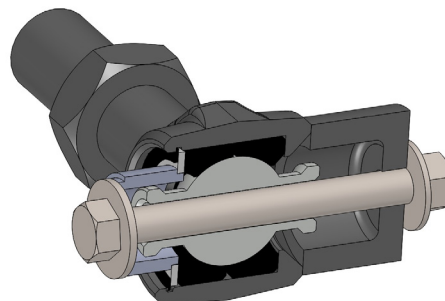

- Place the large nylon cup on the end that will not have the snap ring removed with the cupped end towards the flex eye as shown.

- Place the appropriately sized machined tube into the washer on the side that will have the snap ring removed.

The large machined tube is designed for 1-3/8" ID washers.

The small machined tube is designed for 1-1/16" ID washers.

- Using the appropriate hardware, hand tighten the bolt and square the flex eye removal tool to the eye.

7/16" hardware is designed for small flex eye.

1/2" hardware is designed for large flex eye.

□ 2. FLEX EYE DISASSEMBLY

- Tighten with wrenches (avoid using an impact wrench) to compress the bushings enough to relieve pressure on the snap ring to allow for removal.
- Using snap ring pliers, compress the snap ring and remove it from the flex eye.
- Remove the bushings and retaining washers from the eye.

Note: On some track bar applications it may be necessary to remove the grease fitting to allow for bushing removal.

□ 3. FLEX EYE ASSEMBLY

- Re-install the bushings and washer(s) back into the flex eye in reverse of disassembly.
- Assemble the tool to the eye using the same process shown previously.
- Tighten the bolt until the snap ring can be installed in the groove.

Make sure the snap ring groove is not damaged before proceeding

- Using snap ring pliers, install the snap ring. Verify it is fully seated.
- Loosen the bolt and remove the tool from the eye.
- Grease bushings using a grease gun and non petroleum based grease.
- Clean any corrosion or debris from the inner surface.

□ REINSTALLATION

- Reinstall the control arm onto the vehicle.
- Safely lower the vehicle to the ground and torque mounting bolts to spec.
- Original installation instructions can be referenced if necessary.

If you encounter any problems with your installation and setup, please contact JKS Manufacturing for technical assistance.

JKS Technical Support	
Phone	517-278-1226
E-Mail	jks@sporttruckusainc.com

©2016 JKS Manufacturing Revision Date 3/11/2021